



Rather Be Fishing?

Cabela's, the world's foremost outfitter for hunting, fishing and outdoor gear, has made quality products one of its core values since its inception in 1961, when the company was started on Dick and Mary Cabela's kitchen table. Today, as the nation's largest direct marketer of outdoor outfitting merchandise, Cabela's ships over 7 million customer orders every year through its catalogues and web site, and completes in excess of 6 million sales transactions through its nine mega-store retail outlets.

Because of the rigors of outdoor outfitting, and the superior quality demanded by their customers, Cabela's fishing gear designer, Chuck Villarreal, is always looking for ways to improve their product line and get new designs to market faster.

Classically-trained, Villarreal wasn't thrilled about moving to CAD from his t-square and drafting board. He found it cumbersome and unwieldy to accomplish his designs...until he found Ashlar-Vellum™ Graphite™.

"This program was so simple to learn I was productive in two days. Later, after attending training I became a rocket."

Villarreal found Graphite to be a perfect match for his job of writing technical specifications and developing new products for the Fishing, Marine and Hard Goods divisions at Cabela's. As one person trying to keep up with literally thousands of items, he requires a program that gets the job done quickly, with the highly accurate, detailed manufacturing drawings he demands. Says Villarreal, "Graphite's 2D and 3D wireframe capabilities, along with the many features and file translation capabilities, are perfectly suited to allow me to do just that."

Graphite's unique user interface allows Villarreal to think through his ideas as he works, perfecting the design without worrying about how to run his software. All other CAD packages offer far less flexibility in moving from concept through completed drawing. Because of Graphite's supreme accuracy as a CAD package, Villarreal can send his designs directly to manufacturing with confidence.



Chuck Villarreal, fishing gear designer for Cabela's, lands an over 30 pound Mahi Mahi using gear designed in Graphite.

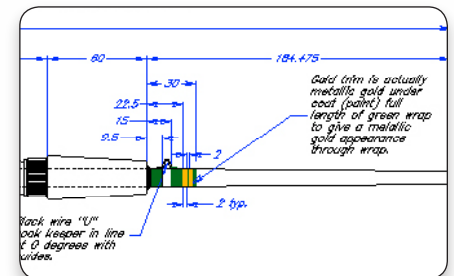
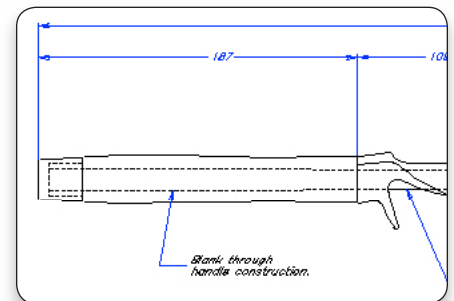

Details of a precision drawing for a new fishing pole designed by Chuck Villarreal in Graphite.

Background/Contact:

For more details on this project contact:

Cabela's
One Cabela Dr
Sidney, NE 69160

Phone: 308-254-7992

E-mail: cvillar@cabelas.com

