

# The Design Explorer

## The Ashlar-Vellum User Newsletter

Second Quarter, 2015

### Gerry Yarrish Mentions Graphite<sup>TM</sup> in *Model Airplane News*

With a passion for radio control airplanes and as an Ashlar-Vellum Graphite user, Gerry Yarrish is also the Senior Technical Editor for *Model Airplane News* and *Electric Flight Magazine*. He recently published an article on using CAD for developing scaled radio controlled airplanes. Importing drawings for full-size planes, Gerry shows how to trace over them in Graphite and develop them into a plan for construction.

Take a look at the full article [here](#).

We hope to feature Gerry in a full success story in our next edition of *The Design Explorer* in September.

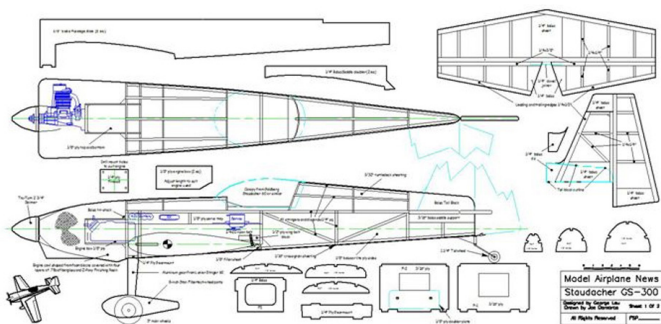

**Above:** This Staudacher plan was drawn by tracing and modifying a set of 3-views drawings.

**Below:** Rib outlines.

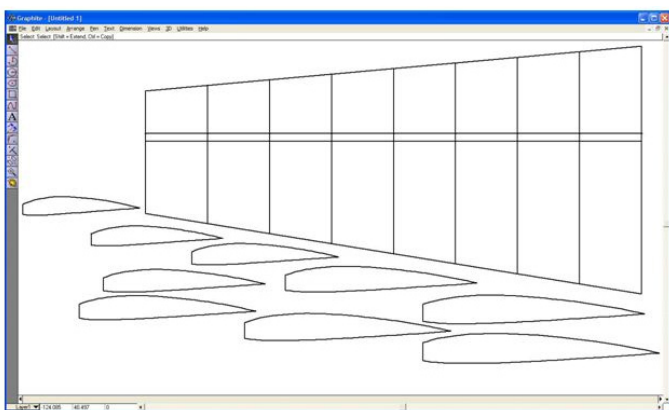

### Welcome Elmo Marquez

Elmo Marquez has recently joined our support team. A native of Berga, Spain, Elmo lives in the Philippine Islands from where he's able to offer extended support into the evening hours, in both English and Spanish. He is experienced in IT, particularly for call centers doing telemarketing, customer service and support. Elmo loves the beaches and water sports of the tropics and enjoys travel, movies and spending time with friends. We're happy to have him aboard.

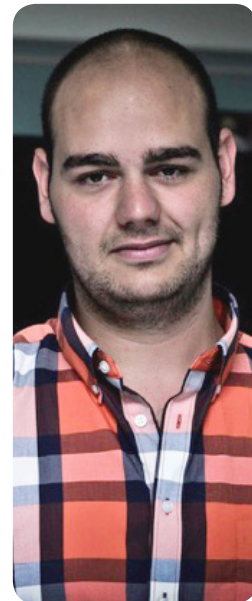

### Graphite v9 SP2

Service Pack 2 of Graphite v9 was posted to our website ready for download. This is a wrap up of various point releases from SP1 plus a couple of other items into one release so you can easily tell that you're always on the latest version.

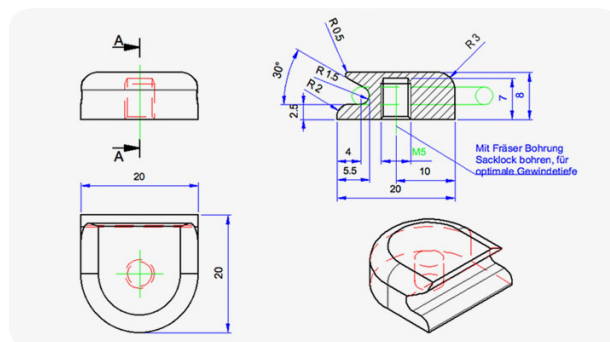

The Ski Piercing. Designed by Walter Arnold using Graphite CAD.

## New Videos

New videos are being posted to our YouTube video channel. Recently a tribute to our users and their many industries was posted. Also posted was Part 1 of our updated Introduction to the Interface and Key Features of Cobalt<sup>TM</sup>, Xenon<sup>TM</sup> and Argon<sup>TM</sup>. Several more videos are in progress.

[Click here](#) to see the tribute to our users:

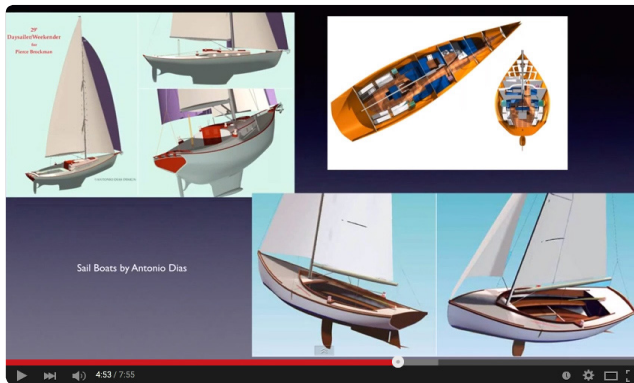
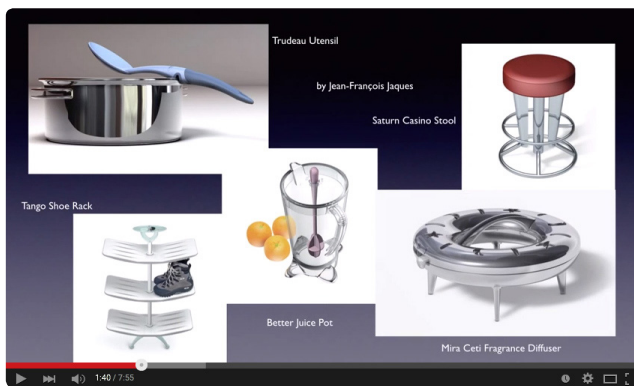

[Click here](#) to see the first part of our Introduction to the Ashlar-Vellum Interface and Key Features video.

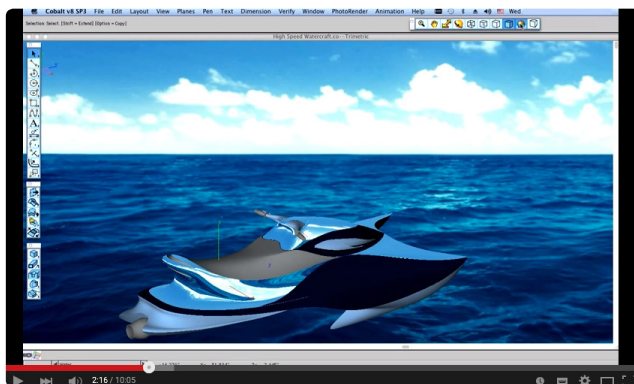

## Kinetics<sup>TM</sup> v2

Version 2 of our Kinetics motion simulation software is being released and should be ready for download. This new version features:

- An improved simulation workflow for easier set up of mechanical systems.
- Improved simulation with new joints including gears and pulleys.
- New interactive simulation allows you to control mechanisms with a joystick or game controller.
- New exhibition mode to easily showcase your 3D renderings, simulations and animations using customizable tools and full screen utilization.
- Shared resources across your organization using libraries of materials, models, backgrounds, and more.
- Better usability includes larger 3D area, improved library navigation and enhanced toolbar support.



## Graphite v10



We will shortly begin work on Graphite v10. In 1996, long before Robert Bou or any of the rest of us were associated with Ashlar, the Vellum® 3D software was released with polygonal surfacing, similar to what is now used in Sketchup. The derision from our customer base, who thought that the Class A surface modeling found in Alias Studio was the only kind of surfacing the world would ever want, caused Ashlar's former management to abandon it and focus on the NURBS solid and surface modeling we have now in Cobalt, Xenon and Argon.

Then Sketchup came along and took the world by storm, until it got lost in hallowed halls of Google and now Trimble Navigation, and left to languish. Enter Graphite v10, same light weight polygonal surfacing, same easy Vellum interface. Watch this space for information as it becomes available.

## Vellum Nitrogen™

Vellum Nitrogen v9 SP2 addresses a number of issues unique to our Asian languages version of Graphite v9. Specifically there are fixes to two-byte characters, Asian language colors and file name characters. These enhancements will be added to Graphite, probably in v10. If you have need of an Asian language edition of Graphite, contact Ashlar-Vellum and we'll put you in touch with Comnet, our distributor for Vellum Nitrogen.

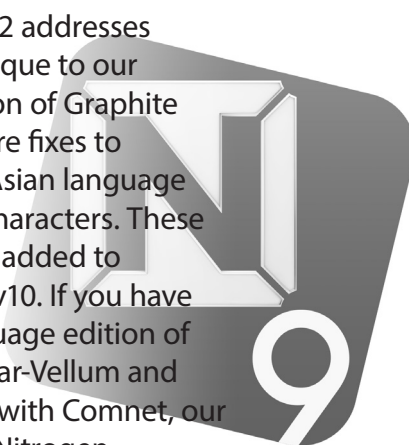

## Call for New Gallery Graphics

Ashlar-Vellum always loves to have new graphics in our Gallery. If you've got a design that you'd like to share, using any of Ashlar-Vellum's precision design and engineering products we'd be proud to post it. We try to always include the name of the designer when using any of your work in our marketing materials.



Scott Krebs



Celso Santos & Christian Albanese



Michele Fremont

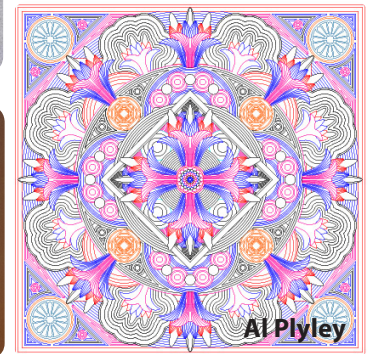

Al Plyley

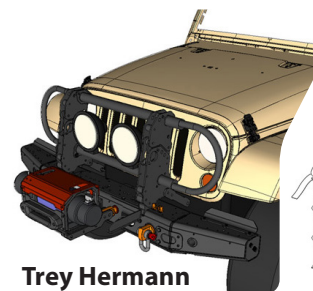

Trey Hermann

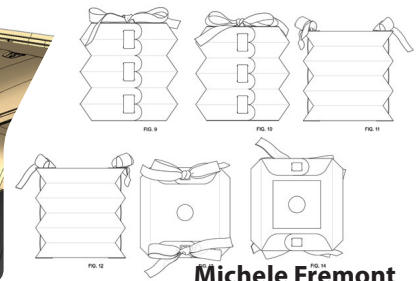

Michele Fremont



Ken Ballard



John Houlihan

## Bou to FESPA

Last month, Robert Bou attended the FESPA 2015 exhibition in Cologne, Germany. FESPA is the largest event focusing on print services for digital, screen and textile formats with over 700 manufacturers and suppliers to the print industry. Zünd showed our newest technology developed for them for 3D assembly of flat designs from Adobe Illustrator for floor stands and sales displays. This technology will then be added customized versions of Graphite in the future. If you have the need for customized applications built on a CAD or 3D modeling engine, Ashlar-Vellum would love to consult with you.

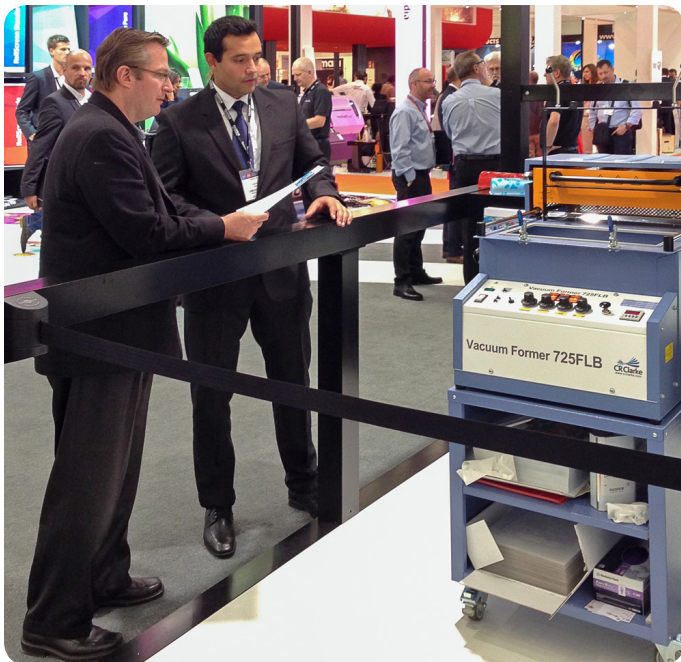

Robert Bou, left, talks with a representative from Fujifilm Europe.

## Graphite v7 Soon to be Obsolete

The last sales of Graphite v7 without an automatic upgrade to v8 ended in December 2006. Therefore, the 10 year mark for v7 is fast approaching in December of 2016. Please be aware that if you're still running Graphite v7 it's time to upgrade before your software becomes obsolete and you are no longer eligible for the \$697 upgrade price. While the cut off date is not for another 18 or so months, it's important to start moving in that direction now.

## User Tip: Stroke Commands

Use the stroke commands in Graphite, Cobalt, Xenon or Argon to zoom in, zoom out and zoom previous. These shortcuts allow you to perform the command while you are in the middle of an operation. In other words, stroke commands suspend one operating state so that you can perform a separate operation, such as a stroke zoom, and not lose the original operating state, such as drawing a line.

Hold down the Ctrl+Shift keys on the PC or the Command key (⌘) on the Mac. Then drag the cursor diagonally across the screen as shown below. When you hold down the appropriate keys, the cursor becomes the cloverleaf shape indicating that the original operating state is interrupted and the stroke command can proceed.

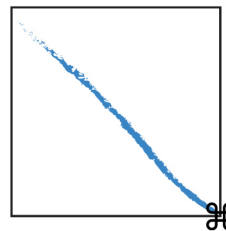

**Zoom In:** Upper left to lower right zooms into your drawing centered over the stroked area.

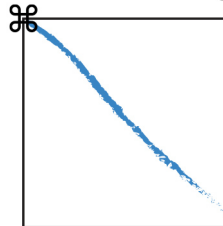

**Zoom Out:** Lower right to upper left reduces the zoom in to previous viewing magnification.

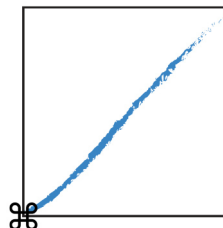

**Reduce:** Upper right to lower left zooms out reducing the current screen to the size of the area defined by the stroke.

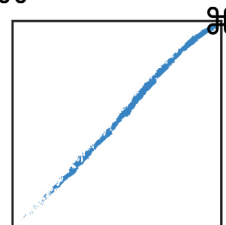

**Zoom Previous:** Lower left to upper right reverses the zoom out to the previous viewing magnification.



## Students Get Down to Business with Graphite™



*School House Graphic Products is a self-sustaining business managed and operated by the students of Arnold High School in Arnold Nebraska, population 600. Using Graphite precision CAD software and an array of equipment, these young entrepreneurs produce signs, trophies, furniture and other products under the supervision Clay Mohr, shop teacher and Julie Mohr, art instructor.*

The Mohrs started using Ashlar-Vellum software many years ago in their classrooms. About 12 years ago they got the idea for the student operated business. Earning college credit and a summer stipend, the students keep the shop running year round now to support their customers.

Students use a 25-pack of Graphite on the Mac and an array of printers, lasers and CNC machines, all purchased from the profits generated by supporting the production needs of local government, businesses and non-profit organizations in their area. Ashlar-Vellum's easy interoperability with other software allows them to design in Graphite, add graphics in Adobe, then output to whatever is needed to drive their equipment.

The list of projects includes car graphics, signage and plaques. This year the students are doing the school's gymnasium cutting vinyl designs for the floor, mats and signage. Other projects include bunk beds and a child's chair puzzle, assembled without metal connectors.

Students start using Graphite in the 6<sup>th</sup> grade with Introduction to CAD Drafting & Design. By the 8<sup>th</sup> grade they've taken on a design project that can be produced in-house and sold commercially. Requirements include figuring the cost of materials and profit margin.

Clay says the students find Graphite a very useful tool for solving geometric problems:

***"The beautiful thing about your program is that I don't have to spend a lot of time teaching software. I get to teach drafting. It's very user friendly."***

Next year the Mohrs hope to upgrade their Vetric software for their CNC router and dedicate time for designing in Cobalt 3D modeling software.

After graduating from Arnold High students often go into the trades, or study engineering. Many of them simply use their design and production skills avocationally. But the skills they've learned in applied mathematics and problem solving, set them well ahead of others. Clay tells us:

***"Our kids really know what it takes to end up with an end product."***



Students design and apply vinyl art and lettering for the local fire department as part of their self-sustaining business.

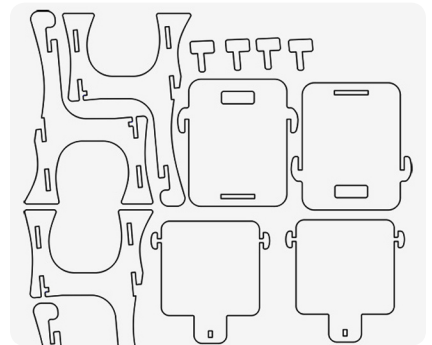

**Above and below**, a child's puzzle chair put together without metal fasteners.



### Background/Contact

For more details on this project contact:

**Clay Mohr, Julie Mohr**  
**Arnold Public Schools**

405 N. Haskell  
Arnold, NE 69120  
(308) 848-2226  
[cmohr@esu10.org](mailto:cmohr@esu10.org)

## A Feather in His Double Lens Cap



*Photographer, drafts person, designer and inventor, Scott Krebs started his career taking photos. Photoshop classes at his local art college opened doors to learning drafting software while later working for an engineering firm. Soon, he was running the electrical design department using things like AutoCAD, MicroStation and lighting photometric software.*

*On his own, Krebs has designed several lighting products to solve problems as a photographer and started a company called Saberstrip to market some of them. Krebs has made a career in engineering, but photography has remained a large part of his life.*

Krebs found Ashlar-Vellum Xenon™ CAD and 3D modeling software when he was looking for design software for the Mac. He found that it had all the functionality that he expected from the “big-name” software, he liked the intuitive interface and the Design Explorer. He especially liked the fact that he could rent it on a monthly basis. Even after using it for a couple of months, Krebs tells us:

***“I felt a little suspect that I was going to want to be using something like SolidWorks later, but I haven’t found that to be the case. I like the way the software works.”***

Always on the leading edge of innovation, Krebs recently changed from his digital single lens reflex (DSLR) camera to the smaller, lighter mirrorless camera and lenses of the Fujifilm X Compact Systems Camera (CSC). Originally wanting lighter weight gear for hiking and travel, Krebs found that the quality was high enough to match his professional Nikon equipment and decided to do a total switch over.

Like many photographers, Krebs is always juggling between lenses. A double-ended lens cap makes it easier for photographers to change lenses with one hand without dropping their valuable equipment. Unfortunately, since the Fujifilm X CSC was so new, it wasn’t likely one was available. Krebs saw this as an excellent opportunity to model something and upload it to Shapeways for a one-off 3D print. It was only after he’d quickly modeled the lens cap in Xenon and got a price from Shapeways that he searched the web to confirm that one was not available.

He’s since started offering the lens cap for sale on Shapeways.com to other photographers for a minimal markup over the 3D printing price.

Krebs also uses Xenon to prototype parts for Saberstrip. He’s been pleased with his experience using Ashlar-Vellum Xenon and has recently converted from a monthly rental to a permanent license. He tells us:

***“I’ve been most impressed with the company as a whole and the software.”***



Doubled-ended lens cap with two lenses for the smaller mirrorless Fujifilm X Compact Systems Camera.

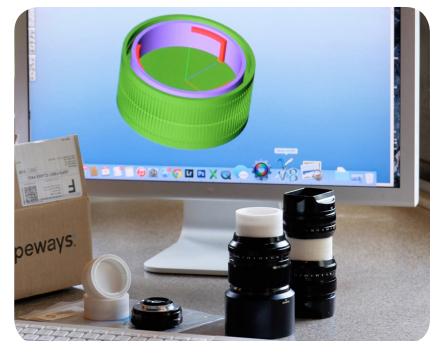

The double lens cap modeled in Xenon.



A double lens cap allows Krebs to change lenses with one hand without dropping his valuable equipment.

### Background/Contact

For more details on this project contact:

**Scott Krebs**

**Saberstrip**

818 7<sup>th</sup> Street North

St. Petersburg, FL 33701

(727) 479-3467

[scott@saberstrip.com](mailto:scott@saberstrip.com)