

# The Design Explorer

---

## The Ashlar-Vellum User Newsletter

First Quarter, 2013

### Ashlar-Vellum Receives Frost & Sullivan Award



**F R O S T**   
**S U L L I V A N**

Remember that “stealth” award we told you we’d received last fall? The one that we were not allowed to even mention the name of the awarding firm unless we paid them \$40,000 for the honor? Well, guess what, after four months they came back to us and gave us a “one time offer” allowing us to announce it for free. So here goes: Ashlar-Vellum is proud to announce the receipt of Frost & Sullivan’s 2012 Global Product Differentiation Excellence Award in CAD & Modeling Software from their Global Best Practices Research team. Highlights from the report are included below:

“Ashlar-Vellum’s Organic Workflow product suite has the unique quality of being not just a feature, but a philosophy—one that encapsulates the essence of a truly creative design process that engenders innovative product designs. This concept design phase has so far not been properly leveraged in other companies benchmarked by Frost & Sullivan competitive analysis, due to schedule and cost constraints and established product development workflows.”

“In comparison to other market participants, Frost & Sullivan points out that what Ashlar-Vellum has accomplished in its Cobalt product with the Organic Workflow design process is true differentiation by providing design software that is modeled after realistic, human creative product development process. This solution does not impose a fixed design process on the user. Cobalt essentially behaves like an intuitive extension of a creative designer’s internal thought process during conceptualization and design.”

“Another key differentiating factor setting Ashlar-Vellum above the competition is that the firm offers rendering and animation in the same software, without even requiring users to switch the mode of use.”

“Ashlar-Vellum’s Organic Workflow enables an iterative design process in a non-linear workflow, so that a designer has the freedom to make changes freely and move in any direction without losing any parametric history, which is instantly available when the user requires it via the ‘Parametric History on Demand’ feature of the Organic Workflow. This creates a design process that is simple and flexible. Cobalt, Ashlar-Vellum’s 2D and 3D modeling software, embodies the Organic Workflow philosophy comprehensively through a rich set of modeling tools.”

“Ashlar-Vellum’s Organic Workflow proves that the vendor genuinely understands its customers, which are concept designers, product development process and challenges. This is evident in its holistic, transparent, comprehensive, and, above all, flexible solution.”

“The primary difference between Ashlar-Vellum’s product and other solutions available on the market is not the depth of Cobalt’s features, but the availability of all the features in a holistic, transparent way that enables the user to create concepts in an intuitive, unobstructed manner.”

“Ashlar-Vellum offers one of the most accessible user-interfaces among CAD products. In addition to user-friendliness, Ashlar-Vellum has designed its Cobalt product to be “transparent” to the user, such that it disappears into the background and minimizes any obstruction to the user in focusing on the project itself.”

## Welcome Jane

Jane Zakharova has joined our AlphaCorr team as Account Manager. She'll be the organizational force behind AlphaCorr sales, keeping Mike Collins, Robert Bou and Vladimir Karpenko on track. Jane comes to us from Mobisoft. She's fluent in three languages and functional in three more. She is skilled at working remotely, having done so since her university training and on through her last couple of career moves. Always interested in trying something new, Jane's skills will be a welcome addition to our AlphaCorr team.



## Welcome Les

Alexander Shcherbakov, better known at Ashlar-Vellum as Les, is moving into Technical Assistance, primarily focused on Cobalt<sup>TM</sup>, Xenon<sup>TM</sup> and Argon<sup>TM</sup>. He'll be using his experience as an Ashlar-Vellum developer to see that bugs are fixed and enhancements implemented effectively. We are glad to have Les' enthusiasm and expertise in a more customer-facing role as he helps us make our 3D modeling software even more productive for our customers around the world.



Robert Bou (right) works with Aleksander Shcherbakov to map out features for v9.

## TeraViks Score in Robotics Regional

Ashlar-Vellum is a proud sponsor of Cœur d'Alene High School's TeraViks, the FIRST Robotics Team 3145 from northern Idaho. The student robotics team used Graphite CAD software to complete the design and demonstration of their 2013 entry. Each year, a different challenge is set to build and program a robot that will perform some variety of functions. This year's competition, called "Ultimate Ascent," had two primary tasks. The first



RoDeL, the First Robotics Team 3145 robot by students at Cœur d'Alene High School.

was scoring points by shooting Frisbees at various goals. The second was climbing a 90 inch tower in three levels at 30, 60 and 90 inches.

Nineteen students worked together on the team's design that precisely shot disks, losing by only one goal, and climbed to the top level of the competition's pyramid with the 118 pound robot. In the Oregon Regional matches, the team scored second in the finals, was awarded the Xerox Creativity Award for design and design process, and received two peer awards for Spirit and Image from teams in the Portland region.

Look for a full story about the team's success with Graphite in the near future on our website and in next quarter's *Design Explorer*.



## Racing Rat Trap Design

Best of Show winner, Eric Ogaz, used AlphaCorr Rules and Ashlar-Vellum Graphite CAD software to design his mouse trap racer for Mr. Burke's 8th Grade Science class at Alta Loma Junior High in southern California.

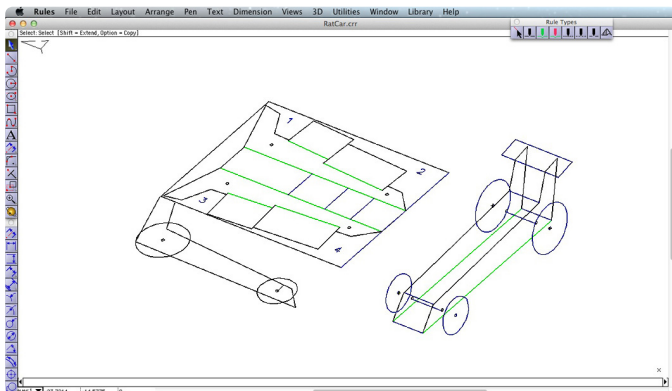

Eric's CAD design of his mouse trap racer.

Eric told AlphaCorr's Michael Collins, "I also got 3rd place for distance, but the teacher and the teacher's aid got 1st and 2nd, so I got 1st place for students."

Eric's car, powered by a Tomcat wooden rat trap, had a Mylar-coated, foam core body. The wheels, also of foam core, used rubber bands for added traction, and skateboard sealed wheel bearings on the axles.



Mounting the rat trap engine.

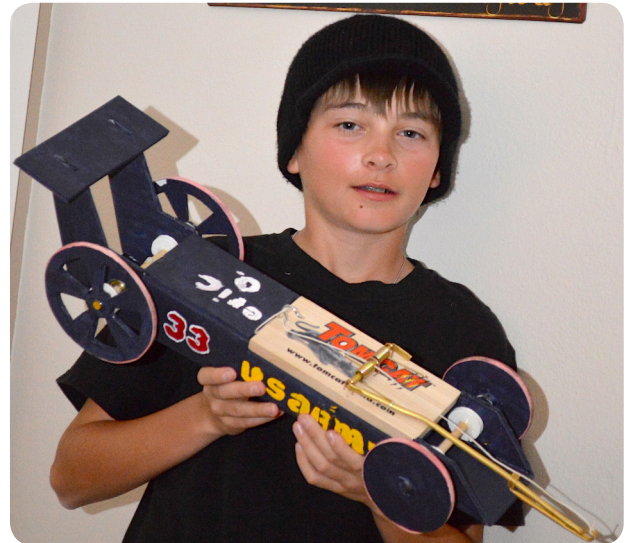

The proud winner and his excellent design.

## Robert Bou to SPAR International



Ashlar-Vellum president, Robert Bou will be attending the [SPAR International](#) conference next month in Colorado



Springs with other 3D professionals from around the world. This year's conference, "End-to-end 3D: Capture, Process, Deliver" will feature the newest technologies and workflows to drive efficiency, reduce timelines, save money, improve safety and mitigate risk across diverse business segments of the 3D market.



## Lounging in Luxury



*Award winning designer Mark Robson has received world recognition for his luxury designs of indoor and outdoor furniture.*

Born in Hertfordshire, England, Robson lives and works in Lovagny, France, not far from the borders of Switzerland and Italy. As a freelance furniture designer, his talents have been sought by some of the top luxury furniture companies around the world including Bemis Manufacturing, Faversham Furniture Group, Flair, Fiell Gallery, Geromeubles, JLS, Sifas, Scab and Zanotta.

Robson started designing in 2D CAD on the Mac using Ashlar-Vellum's DrawingBoard<sup>TM</sup> in the early 90's. When he decided to make the move to 3D modeling several years ago, colleagues advised him to switch to a PC and buy Rhino. Robson, commented, "I know designers who needed to go back to school to learn how to use Rhino! Staying with Mac narrowed my choices, but I had confidence in Ashlar-Vellum and have no regrets with Argon<sup>TM</sup>."

Most recently, Robson designed the Kolorado furniture range for Sifas, a French furniture company, and leader in the In-Out Attitude of home furnishings. The In-Out Attitude seeks to abolish boundaries, making it difficult to determine where the house ends and the garden begins. The Kolorado line includes a chair, lounge, low table and stool.

Robson used Argon 3D modeling for everything including conceptual drawings, initial prototypes, modifications and detailed plan drawings for industrial prototypes. He even created animated Quicktime VRs of furniture before manufacturing.

***"The seemingly simple, curved-slat surface of this furniture range would have been difficult to calculate precisely without easy-to-use 3D software like Argon. Each central slat is identical."***

The furniture met with great success at its launch at the Maison et Object exhibition in Paris. Much of the pre-sales communication used photorealistic renderings done in Argon.

Robson continues designing furniture in Argon for both commercial collaborations and his own personal experimental research in his quest for innovative design ideas.



Robson's Kolorado Lounger uses central slats of identical size, calculated precisely in Argon 3D modeling software.



Testing the precision of the 3D design during prototyping.

### Background/Contact

For more details on this project contact:

**Mark Robson**

89 Chemin de la Combassiere  
74330 Lovagny  
France

+33 6 88 13 67 52

[markrobson@wanadoo.fr](mailto:markrobson@wanadoo.fr)

[www.markrobson.fr](http://www.markrobson.fr)