

The Design Explorer

The Ashlar-Vellum User Newsletter

Second Quarter, June 2005

Into the Light

By Julie Bou

It is time to share the news about several important developments at Ashlar-Vellum. While some of the victories are small, all of this is very good news indeed.

Ashlar, Incorporated to be Sold

The board of directors of Ashlar, Incorporated has recently accepted an offer to sell all assets to Vellum Investment Partners, LLC. Vellum Investment Partners

is currently made up of Robert Bou and Julie Bou who will hold 100% of the stock. The deal is still in process and approval by the stockholders is required.

Robert Bou, former president of Ashlar, Incorporated, will continue in his position, assisted by myself, Julie Bou, as communications consultant. Says Robert, "We are very excited about this new opportunity to take full control of

the destiny of Ashlar-Vellum. Now we can concentrate on steady, incremental growth."



New co-owners Robert and Julie Bou are committed—or maybe should be.

New Development

Our development team has been hard at work completely redeveloping the infrastructure of our modeling software to make this next version rock solid. While it's taken longer than we'd ever dreamed, version 7 of CobaltTM, XenonTM and ArgonTM will be released in mid July. Why has it taken so long? Because the original modeling code was not set up to be worked on by more than a couple of people at once. The underpinnings of the software have now successfully been completely re-architected to allow for an entire team of developers to divide and conquer. This will allow version 8

and higher to have new features much faster than ever before.



Going Global

Ashlar-Vellum is opening an office in the Ukraine to add to our development, testing and web resources. Five new people started there the second week of this month and we're actively pursuing several more. We will also be using this office to sell our software within the former Soviet Union.

Winning Legal Battles

As you may know, Ashlar-Vellum is engaged in several legal battles for rights to our name and logo in Germany, the Netherlands and France. We have won each of these cases, some with resounding victories, and are now in the enforcement and collection phase. This is by no means any easier than the previous phase.

We will now continue to pursue the rights to our intellectual property in these countries for Vellum Pro/Draftboard. A crucial

evidentiary step, however, was achieved earlier this year with sworn testimony from a member of the opposition that Draftboard is descended from Vellum Pro, which is descended from Ashlar's original Vellum. We allege that POSH GmbH, formerly Vellum Software GmbH, is providing this software to customers without a license from us.

What does this Mean to You as our Customer?

With the recent victories in foreign courts regarding our intellectual property suits, new resources coming online globally, a new release supported by our restructured software architecture, and new commitment behind the leadership, Ashlar-Vellum is in an excellent position for steady growth over the next couple of years.

We are developing resources that will increase our productivity immensely. This means that new versions will be released with greater frequency, more robust features, and more solid quality assurance. We will become more visible in the market place as well.

Our team is working hard to improve our software, our processes and our customer service. You can get to know a few of them further on in this newsletter.

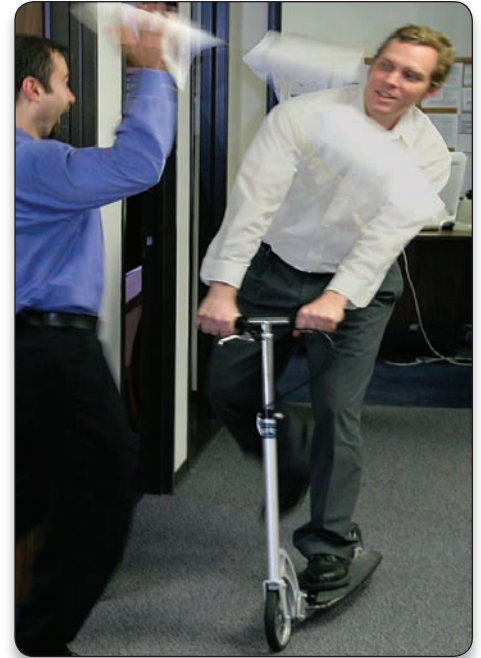

East meets west as Shane Walker, Director of Sales & Marketing collides with Vladimir Karpenko, Managing Director of Ashlar-Vellum Ukraine.

Train in Beautiful Austin, Texas

This is your chance to escape the mid summer blues and spend some time in the warm confines of Austin, Texas.



The average high temperature in May through August ranges from 85°F to 100°F. Days are usually sunny and dry with occasional rain showers.

New Look for the Website

Our website has been updated with a brand new look and feel. If you haven't visited it lately, take a look at www.ashlar-vellum.com. We're excited about the fresh design and improved navigation. If you've sent us images for our gallery that you don't see displayed currently, don't be concerned. Our web team in Kiev is working on expanding the gallery considerably over the summer.

If you have drawings, models or renderings that you would like to see posted in our gallery and

will allow Ashlar-Vellum to use for marketing purposes, please contact Caroline Mills at customer.service@ashlar.com for the correct procedure to send us these images. We require a signed release allowing us to use the images and will give credit to you as the designer. We're especially interested in some new GraphiteTM CAD files.



Sarah Slaughter looks a little tentative about long-distance relationships as she and Vladimir Karpenko develop processes for working with Kiev.

Proclaim your Success

If you've got a story to tell about your design successes and how Ashlar-Vellum software has made your professional life better, we'd like to hear from you. Maybe it's how you were able to think through a particular design problem, how quickly you were able to be productive, or how much time it saved you on a project. No matter the story, we'd like to hear it. We're even willing to reward you in return:

- Every person who enters gets a \$15 iTunes Music Store gift certificate to the largest legal music download catalog in the world.
- Every story that is chosen

for use will receive a new Apple iPod Shuffle (retail value \$99) to play your favorite tunes and transfer files.

Stories will be used by our marketing department on our website, in sales literature, advertising and other communications.

What? You don't think your story, product or drawing is exciting enough? While it's fun to learn about those designing sexy new gizmos, it's the nuts and bolts to which a large number of our users and potential customers honestly relate. Even if you don't think your drawings or models are particu-

larly fancy, we do and we want to hear about them.

To be considered, submit your story in 300 words or less along with an Ashlar-Vellum drawing or modeling file, a jpg of the rendered image (if you're using modeling software), and optionally, a jpg photo of yourself, preferably with the finished product. Be sure to include your name, company name and contact information, especially your phone and email address, to sales@ashlar.com.

Don't worry about how well your story is written. We'll edit it and clear any quotes with you before release. Good luck.

New Releases of Cobalt, Xenon and Argon v7

Version 7 of the 3D modeling products Cobalt, Xenon and Argon is now in beta testing with an anticipated release on July 15th. Greg Morgan, product manager of Ashlar-Vellum commented, "We've

listened to our customers who have told us over and over, 'Never mind the new features, just make it rock solid.' We've done a great deal of work under the hood in version 7. We've strengthened the

infrastructure, improving stability enormously. If you like solid software, you'll love v7." Some of the improved features for v7 include:

Feature

Reworked Infrastructure

Enhanced Undo Feature

Enhanced Visual Selection Tools

Updated ACIS 12 Kernel

Enhanced Design Explorer Feature Tree

Updated NURBS to v3.0

Support for 3D Connexion's SpaceMouse (Windows only v7, Mac coming in v8)

Updated Lightworks to 7.4

Automatic Crash Catcher (Windows only v7, Mac coming in v8)

Enhanced Drafting Assistant

Bug Fixes

Benefit

- Significantly improved stability.

- Improved reliability and speed, often instantaneous on complex parts.

- Better visual selection and manipulation of objects with less confusion.

- Improved translations for STEP, IGES, CATIA v4 and InterOp.
- Improved blending.
- Improved shelling.
- Faster modeling operations.

- Simplified to streamline model management and convey design intent to collaborators and clients (does not apply to Argon).
- Shows material and decal names when accessories are installed.

- Improved Rhino translations.

- Enhanced productivity and comfort for 3D modeling with this high performance motion controller.

- Implemented bug fixes.

- Saves file and operating state before shutting down.
- Allows user to send an automatic email to Ashlar-Vellum support department reporting the problem and last operating state for diagnosis and help from our support team.

- Eliminates annoying drop-outs.

- Over 100 aggravations exterminated.

Upgrade NOW and Save

Upgrade now from any version of Cobalt, Xenon or Argon v6 or from a previous version of Vellum, to Cobalt, Xenon or Argon v7 and save. If you're on an earlier version of Vellum you'll get v6 now and get the upgrade to v7 free,

shipped automatically upon release in July. See the chart below for detailed pricing. But hurry, the day v7 is released the price increases to retail.

Ashlar-Vellum v7 Upgrade Pricing

Customers will receive v6 now and an automatic upgrade to v7 on July 15th. All prices in US dollars.

	JUN-JUL 15	JULY 15th
Cobalt		
v6 to v7	\$595.00	\$695.00
v5 to v6 to v7	\$795.00	\$895.00
98/99/2K to v6 to v7	\$1,495.00	\$1,595.00
Xenon		
v6 to v7	\$495.00	\$595.00
v5 to v6 to v7	\$695.00	\$795.00
98/99/2K to v6 to v7	\$895.00	\$995.00
Argon		
v6 to v7	\$295.00	\$395.00
v5 to v6 to v7	\$295.00	\$395.00
98/99/2K/v5 to v6 to v7	\$295.00	\$395.00
Xenon to Cobalt	\$1,045.00	\$1,095.00
Argon to Cobalt	\$2,745.00	\$2,795.00
Argon to Xenon	\$1,845.00	\$1,895.00
Graphite to Cobalt	\$2,745.00	\$2,795.00
Graphite to Xenon	\$1,845.00	\$1,895.00

Hot Fix for Graphite 7.4.4

We recently posted a hot fix for Graphite on the Mac that eliminates a couple of mysterious problems some of our users were reporting. If you've had difficulties with unexplained crashing or find your text wrapping in odd ways when printing to large paper sizes, you can download the hot fix at:

<http://www.ashlar-vellum.com/sections/support/updates/updates.html>.



Greg Morgan rocks at product management.

Graphite Plug-in for Spotlight

The Graphite plug-in for Mac OS X Tiger's new Spotlight feature is available as a free download from our website. This plug-in allows Spotlight to index and search text inside Graphite files for easy file location. A press release was issued jointly with Apple on Mon-

day, May 2nd, 2005, and sent out over the business newswire. The Ashlar-Vellum development team is also working on a Cobalt plug-in for release in the third quarter.



Website Furniture Feature

Don't miss the furniture feature on the website this month. See how DesignJourney Industrial, G Squared, and Fred Puksta use Ashlar-Vellum to design for the furniture industry.



Interior bedroom design modeled and rendered in Ashlar-Vellum.

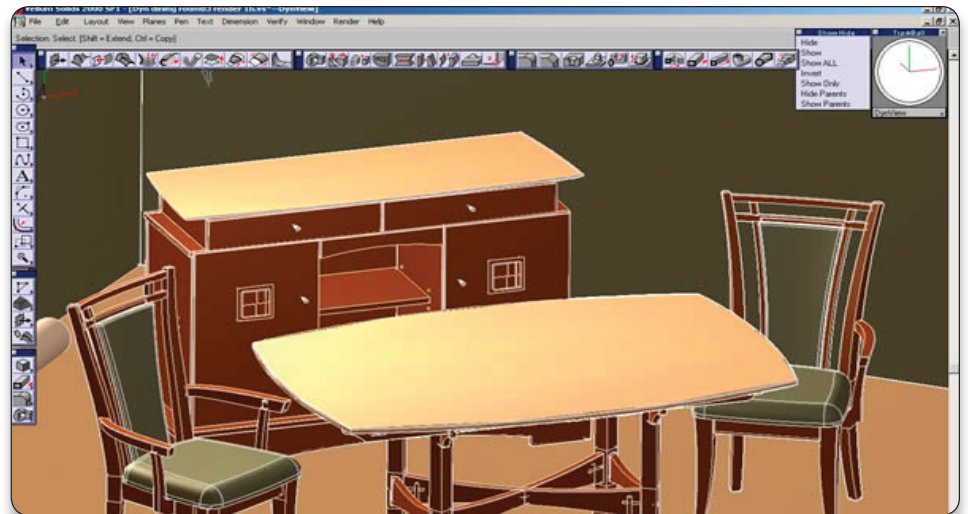

"Constructing the model in Cobalt was easy because it replicated the process of making the model by hand."

Frederick Puksta

"Using Cobalt has allowed me to translate my ideas into reality and to share my visions. Being able to model and photo-realistically render sculptural 3D shapes was very valuable in selling my ideas to others."

Mark Gajewski, G Squared

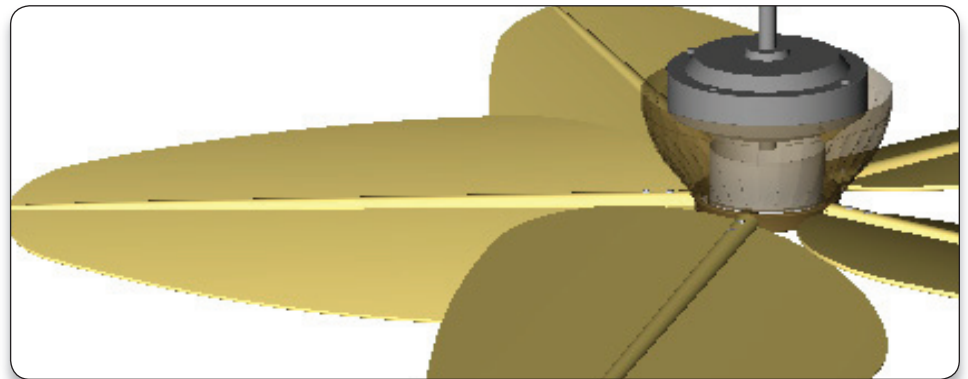

Fan detail by Mark Gajewski of G Squared.

Techniques for Better Drawing & Modeling

In each newsletter we bring you tips and techniques for working more effectively in our software. Below are several tips that apply no matter which of our programs you're using.

Stroke Commands

Use stroke commands to zoom in, zoom out, zoom previous and to create horizontal and vertical construction lines. These valuable shortcuts allow you to perform the command while you are in the middle of an operation. In other words, stroke commands suspend one operating state so that you can perform a separate operation (i.e. a stroke zoom) and not lose the original operating state (i.e. drawing a line).

Hold down the Ctrl+Shift keys (PC) or the Command key (Mac) and drag the pointer diagonally across the screen as described below. When you hold down the appropriate keys, the pointer takes on a cloverleaf shape.

Using Stroke Zoom



Zoom In



Zoom Out



Reduce



Zoom Previous

Upper left to lower right zooms into your drawing.

Lower right to upper left zooms to previous viewing magnification.

Upper right to lower left zooms out reducing the current screen.

Lower left to upper right zooms to previous viewing magnification.

Creating Stroke Construction Lines

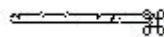

Horizontal Line



Vertical Line

Drag the cloverleaf cursor any length horizontally to create a horizontal line.

Drag the cloverleaf cursor any length vertically to create a vertical line.

Select All Shortcut

The fastest way to select everything in your drawing is to double-click the selection tool.



When you double-click on the selection tool, everything in the drawing (hidden layers and/or objects excluded) is selected, including objects that lie outside of the current viewing screen.

Right-click Menu

Right click in the white space of your drawing to access the shortcuts of Right-click Menu.



Modelling Right-Click Menu

In Cobalt, Xenon or Argon the menu contains shortcuts for changing views and planes, selecting geometry, showing or hiding geometry, zooming and dynamic pan, zoom and rotating.

In Graphite, the menu shows shortcuts for changing views and planes, selecting geometry, spell checking, zooming, changing preferences and dynamic pan, zoom and rotating.



Graphite Right-Click Menu

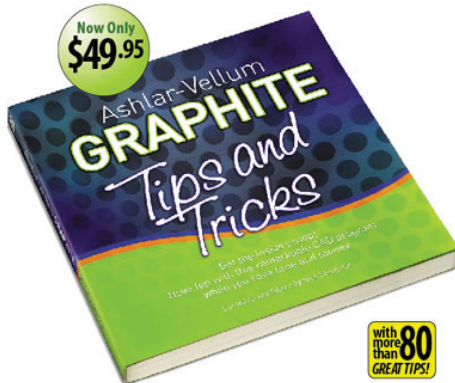

New book Graphite Tips & Tricks

This is it—the tips and tricks to make you a Graphite pro. Work more efficiently and effectively by stringing tools and commands together for powerful performance. Unlock the hidden features of Sheets, Views and Models. The secrets of the experts are now at your fingertips.

Parawhatics?

Who Needs Dimensionally Constrained Parametrics?

Both Cobalt and Graphite contain dimensionally constrained parametrics, a fancy industry phrase for putting mathematical constraints on a design. So what good are these constraints and how do you use them to your advantage? Better yet, how does Ashlar-Vellum software give parametric users the edge over similarly equipped software? Let's talk.

Dimensionally constrained parametrics are good for creating families of parts or models with varying features, but similar designs. Think of a set of wood screws where the head and shank are all the same diameter, but there are 10 different lengths.

True to the classic Vellum interface, Ashlar-Vellum parametrics offer unmatched flexibility to suit your design needs in several ways. First, all parametrics in Cobalt are associative and can be:

- Input directly
- Geometrically-constrained
- Dimensionally-driven
- Equation-driven
- Relationship-driven

In Graphite, parametrics can be:

- Dimensionally-driven
- Equation-driven
- Relationship-driven

Dimensionally constrained parametrics drive the shape of a design

in several ways. One way is by mathematical equations. When one dimension changes, others within the model will change or not, according to the equations established to govern those relationships. For example, the width of an object could be constrained with parameters to always be 30% of the depth. When the depth is changed, the width changes accordingly.

Parametrics also are driven by geometry and relationships. For example, if a hole is designated as centered on a form, it will remain in the center, no matter how that form changes in size or shape.

Parametric support in Cobalt and Graphite is strictly on-demand. Use it or not as you please. This is a major difference from products like Pro-E (the undisputed industry gorilla of this feature), where an entire set of parameters is required before you ever begin to draw. Let's face it, concept sketches are a pain in the mouse with parametrics. When you're still experimenting with your initial design, you want all the flexibility you can get. Many shops using Pro-E turn to something simple like SketchUp for creating fast concepts. Unfortunately, these concept programs lack the accuracy for precision manufacturing.

So when a design is completed, it's turned over to the Pro-E jockeys to document and send to manufacturing. This duplication of effort and resources is completely unnecessary in Cobalt or Graphite. Both programs combine the power of parametrics, the freedom to sketch conceptually, and the accuracy to manufacture with precision.

The relationship and equation parametrics of both Cobalt and Graphite provide greater productivity, faster initial design, and more efficient design iteration. Isn't it time you considered using them?

Unleash your creative genius with Ashlar-Vellum training.



Whether you're a seasoned Ashlar loyalist or only just beginning to understand what you have at your fingertips—a highly skilled, Ashlar professional will help you quickly take advantage of the extreme power behind Ashlar-Vellum's design solutions. Contact **training@ashlar.com** for more information.

Accessorize your Models

Have you seen them yet? Ashlar-Vellum is now offering four hot accessories for use with our 3D modeling programs Cobalt, Xenon and Argon:

- **Vellum:materials** is a collection of prototype surfaces and finishes for easier rendering of virtually any kind of object.
- **Vellum:decals** is a set of 300 commonly used decals including AV, computers, hazard, key-

board and more.

- **Vellum:tracks** has 13 original, royalty-free music tracks for making 3D movies with a really professional touch.
- **Vellum:environments**, our newest release, has 15 virtual photography studios with pre-lit back grounds for easy modification.

one sells individually for \$100 on CD, or \$200 for a site license on CD. See your reseller or contact Ashlar-Vellum to purchase.

Vellum:environments Vellum:tracks



Vellum:materials

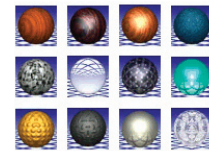

Vellum:decals



Link to our website for complete details on these products. Each

Meet our Staff

Each quarter we'll profile some of our staff members so that you can get to know the people behind the names in our company. We have an especially good staff right now and we're proud of them and the jobs that they do.



Caroline Mills

makes the world go round. As our voice of customer service and operations, she's the one who answers the telephone, extends trial codes, processes the orders, and sorts out the billing irregularities. She's also a huge baseball fan. Take her to any game and she'll be happy, but her heart really lies with our local boys of the Round Rock Express.



Judd Servidio is this month's top sales guy. A professionally trained chef, Judd

finds selling Cobalt to be easier on his feet and less likely to cut off his fingers. Judd loves sports and traveling. He hopes to visit Australia sometime soon.



Sarah Slaughter

heads our operations and is the guru behind our File-maker database. If you've ever owned a copy of our software, you can bet she'll find it. Sarah just gave birth to her second daughter, with Nick barely getting her to delivery room in time. They both agree that turns in hospital corridors should be banked for faster wheelchair mobility.



Nick Slaughter

runs our training and documentation department. He's taught the best and the brightest minds in the industry how to make our software run circles around the competition. If you haven't signed up for one of his classes, now is definitely the time. Nick is also a master builder and a new dad for the second time.



Shane Walker

is responsible for our sales and marketing effort. It's a big job and his hard work is beginning to show. Shane is also a professional musician, and leads the band featured on our Vellum:tracks music CD for 3D movies.

Rather Be Fishing?

Cabela's, the world's foremost outfitter for hunting, fishing and outdoor gear, has made quality products one of its core values since its inception in 1961, when the company was started on Dick and Mary Cabela's kitchen table. Today, the nation's largest direct marketer of outdoor outfitting merchandise, it ships over 7 million customer orders every year through its catalogues and web site, and completes in excess of 6 million sale transactions through its nine mega-store retail outlets.

Because of the rigors of outdoor outfitting, and the superior quality demanded by their customers, Cabela's fishing gear designer, Chuck Villarreal, is always looking for ways to improve their product line and get new designs to market faster.

Classically-trained, Villarreal wasn't thrilled about moving to CAD from his t-square and drafting board. He found it cumbersome and unwieldy to accomplish his designs...until he found Ashlar-Vellum™ Graphite™.

"This program was so simple to learn I was productive in two days. Later, after attending training I became a rocket."

Villarreal found Graphite to be a perfect match for his job of writing technical specifications and developing new products for the Fishing, Marine and Hard Goods divisions at Cabela's. As one person trying to keep up with literally thousands of items, he requires a program that gets the job done quickly, with the highly accurate, detailed manufacturing drawings he demands. Says Villarreal, "Graphite's 2D and 3D wireframe capabilities, along with the many features and file translation capabilities, are perfectly suited to allow me to do just that."

Graphite's unique user interface allows Villarreal to think through his ideas as he works, perfecting the design without worrying about how to run his software. All other CAD packages offer far less flexibility in moving from concept through completed drawing. Because of Graphite's supreme accuracy as a CAD package, Villarreal can send his designs directly to manufacturing with confidence.



Chuck Villarreal, fishing gear designer for Cabela's, lands an over 30 pound Mahi Mahi using gear designed in Graphite.

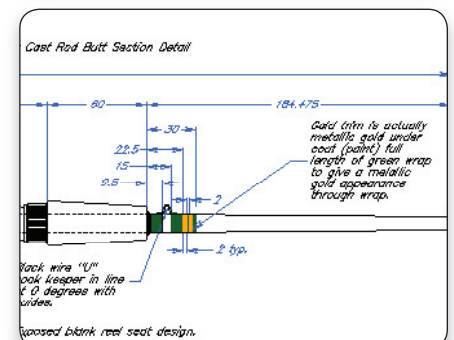
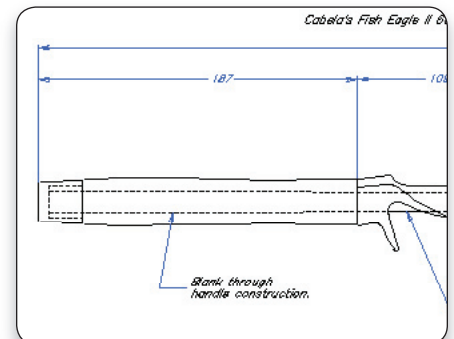

Details of a precision drawing for a new fishing pole designed by Chuck Villarreal in Graphite.

Dare to be Square

From an initial range of traditional freestanding bathtubs, Telford-based Victoria and Albert Bathtubs have expanded into the design-driven market with a range of uniquely contemporary tubs.

Given only the size as a starting point, Kevin Quigley took up the challenge of designing a totally unique and contemporary tub for Victoria and Albert Bathtubs, creating the Capri. Kevin needed to explore options for the basic forms as quickly as possible. With the associative solids and surface modeling features in Cobalt™, Kevin was able to create six different concepts rendered in gray scale in only a few hours. He said that in a product like Solidworks this would have taken an entire day, and each concept would have doubled in time and cost. In addition he said, "Half way through the design process, Victoria and Albert needed to make a significant change to the front of the tub." Because of Kevin's confidence in Cobalt he was able to say, "Sure, no problem."

"In Solidworks this major design revision would have been a serious problem. It would have been easier to start from scratch. But Cobalt's flexible history-tree feature allowed me to make the changes in only half an hour — and Cobalt updated 10 associated drawings automatically!"

Kevin utilized the flexible sectioning feature in Cobalt to allow the Victoria and Albert representatives to see the effect various designs had on material thickness and lumbar support.

The final design for the Capri was developed completely in Cobalt, including the renderings, Viewpoint web viewing files and full production drawings. Kevin commented that, "the Viewpoint export from Cobalt is excellent. You can even get inside the tub!" With the customer based in Telford and the production and tooling facility in South Africa, Cobalt's outstanding viewing files and PDFs of renderings and drawings played a critical part in quickly assessing and finalizing the project.

The final result for Quigley Design? Another success...the Capri is now one of the top selling bathtubs at Victoria and Albert.



Using the associative solids and surfaces modeling in Cobalt, Kevin was quickly able to create several variations of the bath for the client to choose from.

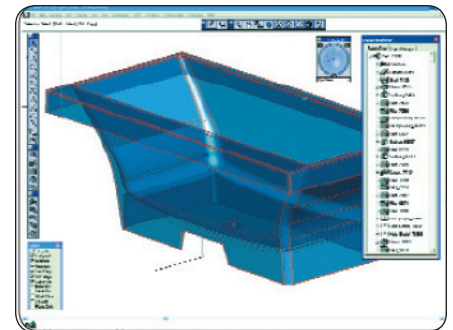

**Call your Value Added Reseller
or visit us online for more
information on the
Ashlar-Vellum product line.
www.Ashlar-Vellum.com
+1-800-877-2745
12710 Research Blvd. Ste 308
Austin, Texas USA**