

The Design Explorer

The Ashlar-Vellum User Newsletter

Third Quarter, 2010

Cobalt™, Xenon™ & Argon™ v8 SP2 r5 Released

Service Pack 2 Release 5 of Cobalt, Xenon and Argon v8 (build 873) was released this month. This version resolved the following:

- Fixed the ability to select sketches.
- Eliminated the new file created when importing a DWF or SAT file into an existing, open Cobalt file.
- Enabled curves, surfaces and solids to be picked for removal when using the Trim Solid tool.
- Added the Construction Line tool to the tool pallet.
- Enhanced grid line order and infinite length.
- Resolved crash issues specific to particular customer files.
- Resolved issues with select DWG files crashing upon import.
- Resolved issues when turning off Model to Sheet layer.
- Resolved materials lost on Undo.



This is a free update to those with v8 licenses of Cobalt, Xenon and Argon and can be downloaded by using **Help>Check Web for Updates** from inside the program.

Graphite™ v8 SP2 r3 Released



864

The latest hot patch for Graphite, build 864, was released in July and is available for download from the website. In this release our development team:

- Implemented Ashlar-Vellum crash reporter with file recovery (Windows only).
- Resolved Apple event error 1708 after printing on Snow Leopard.
- Resolved printing issues under Windows on selected HP printers.
- Solved DWG import issues in Demo mode.
- Resolved a dozen user-reported issues.

This is a free update to those with v8 licenses of Graphite, including those with a courtesy license through their Cobalt or Xenon software, and can be downloaded by using **Help>Check Web for Updates** from inside Graphite.

A Sneak Peek at Iridium™

Engineering insight for product design™



Ashlar-Vellum is preparing to announce our newest software program, Iridium, for product design finite element analysis. Created especially for design engineers, Iridium lets you visually analyze and understand the strength, heat, and harmonic characteristics of designs. Its approachable interface makes FEA useful to validate and optimize designs.

Bring 3D models into Iridium, develop surface and volume meshes, apply boundary conditions and loads, run the analysis, then visualize results. Engineering stress and strain data is visualized in meaningful ways including contour, iso surface, vector and animation.

Iridium's virtual validation eliminates the tedium of doing calculations and analysis by hand, making it easier to spot vulnerable areas and optimize the design, while reducing the number of prototypes.

Available in four feature sets at four different price points, Iridium will initially be a separate program as we work toward tighter and tighter integration within Cobalt. It will also integrate with our Alchemy translator plug-ins, allowing files from other 3D modelling software to be brought in and analyzed.

Putting the power of finite element analysis in the hands of more people, Ashlar-Vellum anticipates the start of beta testing in October. Initially available on Windows, the Mac version will follow around the end of the year.

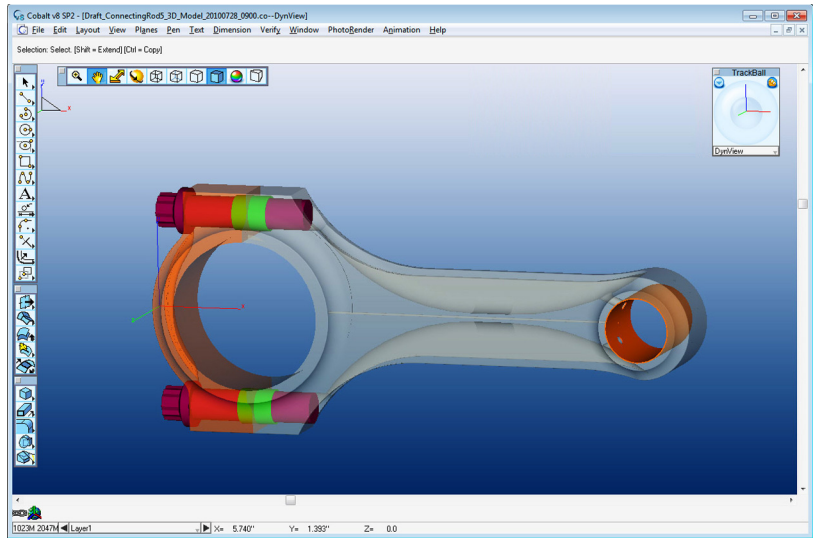

This connector rod was modelled in Cobalt (top) and brought into Iridium for meshing and analysis. The visualizations in Iridium show (middle) the von Mises stress analysis, and (bottom) the displacement.

Continued...

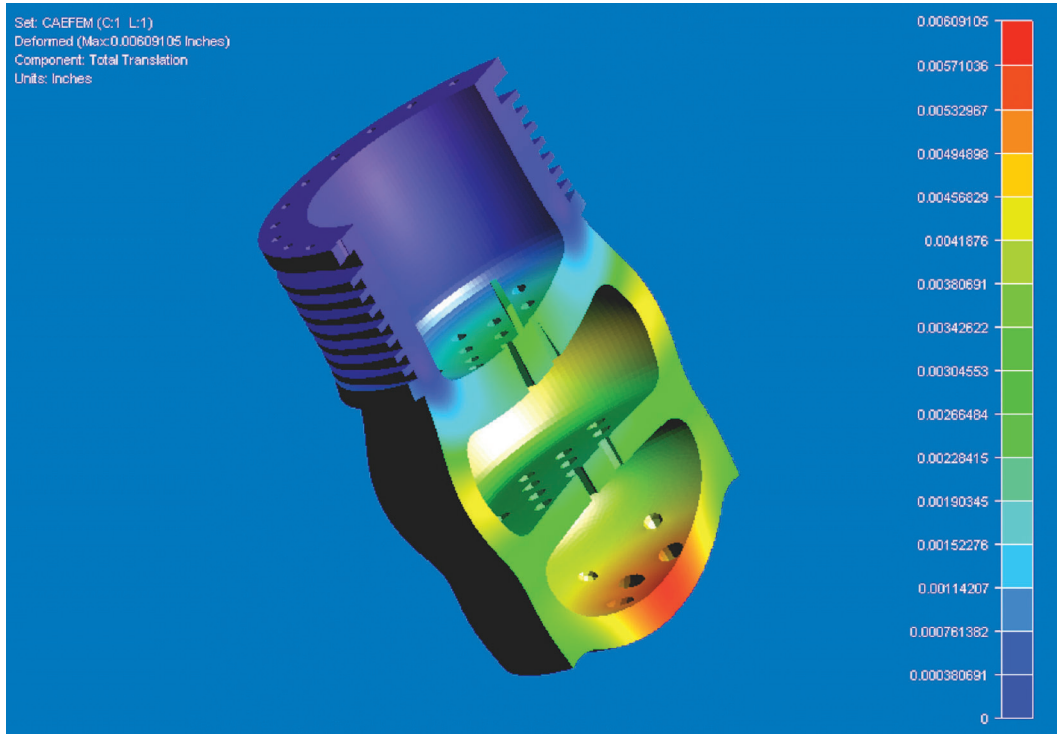

Level Name	Feature Set	Limitations	Price in US\$
Limited	<ul style="list-style-type: none"> • Meshing • Pre-processing • Linear Static Analysis • Normal Modes Analysis • Post Processing 	<ul style="list-style-type: none"> • Parts: 3 per study • Nodes: 25,000 per study 	\$995
Essential	Limited + <ul style="list-style-type: none"> • Buckling Analysis • Steady State Heat Transfer Analysis • Thermal Stress Analysis 	None	\$2,995
Isochronal	Essential + <ul style="list-style-type: none"> • Transient Dynamic Response Analysis • Harmonic (Frequency) Response Analysis • Response Spectrum Analysis • Transient Heat Transfer Analysis 	None	\$4,995
Adept	Isochronal + <ul style="list-style-type: none"> • Nonlinear Static Analysis • Nonlinear Dynamic Analysis • Nonlinear Heat Transfer Analysis 	None	\$6,995

Call for Sketch Rendering for Gallery



Cobalt, Xenon and Argon v8 features Sketch Rendering for stills and animations. This makes it easier for computer-generated models to look hand drawn, giving them an artistic, emotional appeal. If you've effectively used Sketch Rendering for any of your models, we'd love to see them and feature them in our gallery with your permission. Send files to julie.bou@ashlar.com.

Improvement for SolidWorks to .SAT Export

While simple parts are easily exported from SolidWorks to .SAT files, there's been several reported problems regarding complex parts with mirrored surfaces when exported from SolidWorks out to .SAT files.

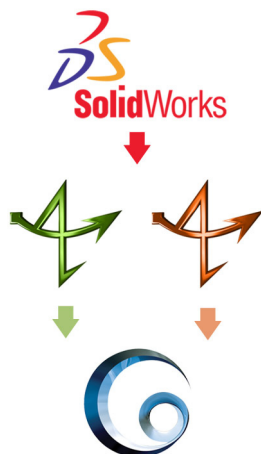

Instead of exporting .SAT files from SolidWorks then importing them into Cobalt, we recommend importing SolidWorks files directly into Cobalt via one of our Alchemy translator plug-ins. Ashlar-Vellum Alchemy:Essential™ and Alchemy:Adept™ use Transmagic technology, a completely different algorithm from that developed by the SolidWorks programmers. So far the success has been excellent.

Mac Cosmetics Training

Nick Slaughter was back in New York City this month offering advanced Cobalt training to Mac Cosmetics, a division of Estée Lauder.

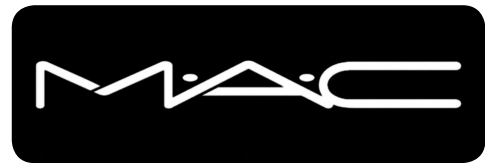

In the advanced course Nick covered things like:

- Strategies for modelling complex shapes.
- Advanced free-form surfacing techniques.
- Working with and controlling tangency of surfaces.
- Workaround techniques for difficult modelling situations including complex blending, chamfering, shelling, Boolean operations and stitching surfaces into solids.
- Lighting and scene set-up for photo-rendering.
- Creating realistic rendering textures.
- Applying decals for logos and imagery on objects including graphics for watch faces, LCD displays, labels, etc.
- Creating animations including QuickTime VR, fly-bys and walk-throughs.
- Outputting 3D models in new 3D web formats.

How to Insert a 3D Object into a PDF File

Just as it's become *de rigueur* to insert still graphics into documents, it will soon become common place it use 3D objects that can be moved and manipulated on the virtual page.

It's easy to insert any 3D model created in Cobalt, Xenon or Argon into a PDF file using Simlab Composer v2 and Adobe Acrobat Pro.

Simlab Composer is available from Simlab Soft on Windows and Intel Mac for \$149. See www.Simlab-Soft.com.

Adobe Acrobat Pro is available stand alone for \$449 but many Ashlar-Vellum customers already own it as part of an Adobe suite of products. The Extended Edition of Adobe Acrobat Pro is not required.

To insert a 3D model into a PDF file, follow these easy steps:

1. Bring up the model in Cobalt, Xenon or Argon.
2. Export the model as a STEP file.
3. In Simlab Composer v2 import the STEP file.
4. Export the file in the U3D format.
5. In Adobe Acrobat Pro open the PDF file in which to insert the 3D file.
6. Using the 3D option within Adobe's Multimedia toolbar, insert the U3D file into the document.

Only viewers that support 3D, such as Adobe PDF Reader (free) can display 3D PDFs. Unfortunately, Apple's Preview for PDF does not support 3D and therefore 3D files will not appear in them.

On the right is the familiar Ashlar-Vellum yo-yo modelled by Troy Starkey inserted directly into this PDF. Use the controls on the frame to move the model as desire.

While plans are on the drawing board to build a seamless 3D PDF export into Cobalt, Xenon and Argon v9, this process can be used in the meantime.

MeshLab can be used in place of Simlab Composer with a VRML (.wrl) file format rather than STEP. Meshlab is available free from www.meshlab.org and works for Windows but crashes on Mac. No word when this problem might be fixed.

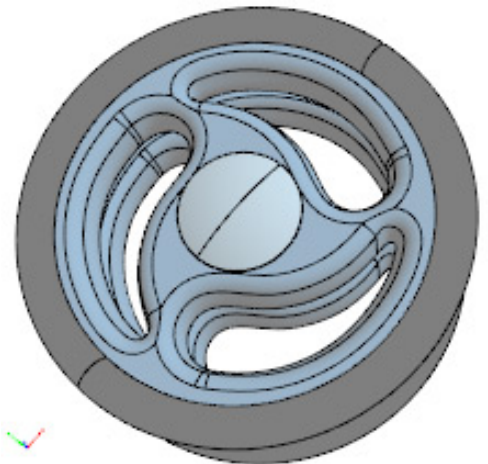

Use your mouse to manipulate the yo-yo embedded as a 3D object in this PDF.

Apple's Preview software which comes free on the Mac does not support 3D, nor does it support layers. Therefore, Ashlar-Vellum highly recommends downloading the free Adobe Acrobat Reader at www.adobe.com and skipping Preview altogether until Apple remedies the situation.

A Stiff Shot of Successo

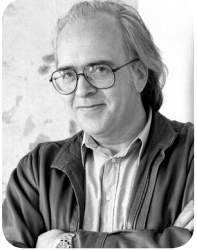

Ashlar-Vellum Xenon™ allowed designer John Bicht of VersaLab to expand his high-end home espresso grinder into a much sought-after professional espresso machine with the design of two important accessories for the commercial coffee market.

Busy running his business, John didn't have much time to work on new design projects, but he had some great ideas for solving several problems inherent in the Barista's job. After being away from the software for a significant length of time, John fired up Xenon and within minutes was productive again.

"It amazes me that I can sit down with a CAD program that I haven't used for five months, because I've been doing other aspects of the business, and within minutes be comfortable again and start doing stuff."

One idea was for a dosing hopper which, unlike conventional grinders, delivers a single dose of beans to the grinder each time, preserving freshness. Pull the handle on the hopper and a premeasured dose of beans goes down the chute and is ground in the portafilter.

John's further idea was a holder for the portafilter. The holder frees the barista's hands allowing him or her to prepare another shot while the first is grinding. When using two machines along with their Versalab Espresso Press a single barista can easily prepare two drinks every 70 seconds, even when each drink requires 30 seconds to pour.

Xenon's incredible power to easily create any shape allowed John to think through his design, coming up with accessories that were pleasing to the eye of the customer and the touch of the barista. As he tells it:

"It's all right there in front of the customer, so it counts a lot what it looks like and what it feels like. So I was able to go, 'Let's make the handle a little longer. Let's make it a little bigger around. That's right. That'll feel better.'"

By developing these two new accessories Versalab was quickly able to move from a strictly high-end home machine into the commercial market, turning their business around and allowing them to not only survive but to thrive in a down economy.

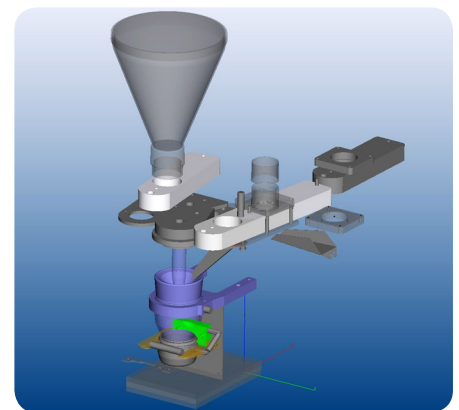
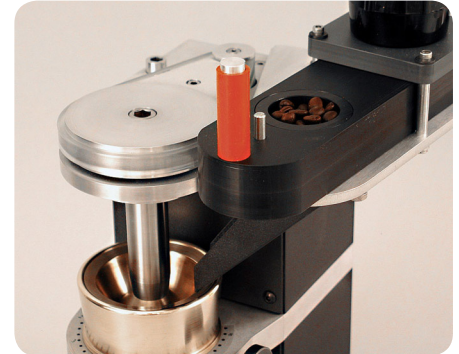

The dosing hopper (top) and the portafilter holder (bottom) are two accessories designed by John for his original espresso grinder, also designed in Xenon (centre).

Background/Contact:

For more details on this project contact:

John Bicht/Versalab

3890 Saulcy Ct.

Loveland, CO 80537

+1 970 622-0240

john@versalab.com